



www.colsafety.com  
(800) 969-5035  
info@colsafety.com

# ASME B30 COMPLIANCE

## ASME B30 STANDARD FOR LIFTING & RIGGING

Chapter 26-5 of the ASME B30 Standard covers rigging blocks, like those that you'd use with a capstan hoist. Here's what you need to know about the standard\*. Have more questions? Give our Gear Experts® a call!

## MATERIALS

The block should be able to permanently deform before losing the ability to support the load. This ensures that you should notice the block has been overloaded before it falls.

Side plates should be of metal, wood, or a synthetic material. You'll almost always see steel or aluminum blocks in the tower industry. The sheaves and load-bearing straps or fittings should be made of metal, as well.

## SAFE DESIGN FACTOR

Rigging blocks must have a minimum safety factor of 4.

## RATED LOADS

Always keep your total load inside of the recommended limits set by the manufacturer. And remember that this is the maximum load applied, not a single line load. Meaning if the block is rigged at the top of the tower and you're lifting something that weighs 1,000 pounds, there could be up to 2,000 pounds on the block. Check out competent rigger training courses for more on these concepts.

## IDENTIFICATION

Each block has to have markings for manufacturer, rated load, and acceptable rope sizes. The block should also be maintained by the user to insure these markings remain legible through the life of the hardware.

## TRAINING

Users must be properly trained to select, inspect, and fully use the blocks. That means not just in proper rigging, but also this very standard.

## INSPECTION, REPAIR, & REMOVAL FROM SERVICE

A qualified person should designate whether the hardware is suitable for rigging, and remove from service if it's not. Prior to use, all blocks should be inspected to verify compliance with ASME B30. A visual inspection should be performed each time the block is used. Permanently installed rigging hardware should have periodic inspections as well.

Repairs or modifications must be specified by the manufacturer or a qualified person. The replacement parts should meet or exceed the original manufacturer specifications. Unless advised by the manufacturer, modifications are not recommended.

## OPERATING PRACTICES

Obviously, load ratings should not be exceeded. Make sure you're keeping clear of the block, its running lines, load, or any other part

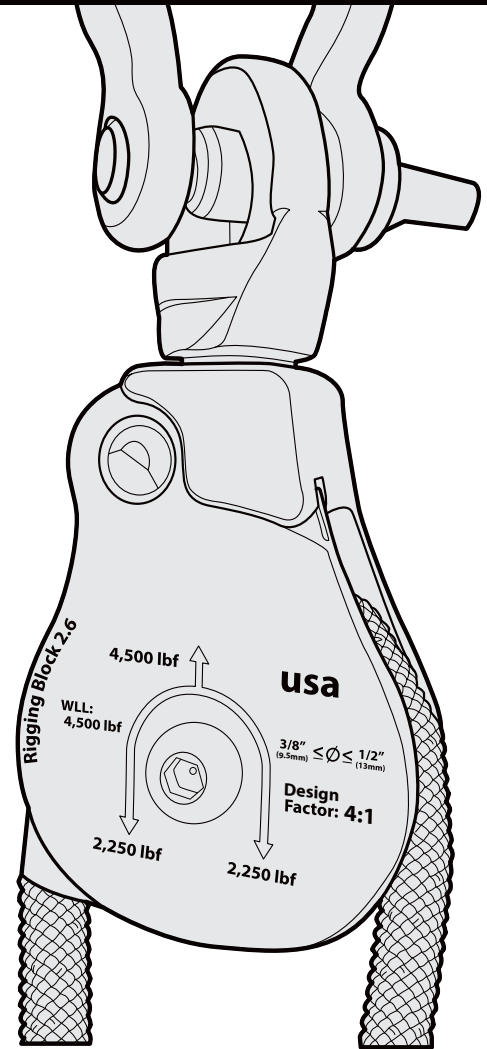

of the system during lifting. That includes walking or standing under a suspended load, or lifting line. Also, don't stand next to the rigging when the line is under tension.

The load applied to the block should be in-line with the sheave to prevent side loading. Blocks with swivels help to avoid these problems. Also, make sure your rope is securely in the groove of the sheave. Shock loading should also be avoided.

\*This is not a comprehensive training guide.



LOOK FOR THIS BADGE THROUGHOUT THE CATALOG.

